



THS 21 SERIES

Quality Control at its finest



MULTI-SPECTRUM INDUSTRIAL METAL DETECTORS

FEATURES

- Unique detection capability of magnetic, non-magnetic and stainless steel metal contaminants
- Extremely high adaptability to any product to be inspected
- FDA Title 21CFR Part 11 compliant:
 - ✓ Data Security
 - ✓ Data Integrity
 - ✓ Data Traceability
- Rugged AISI 316L stainless steel construction and food-compatible plastic parts [EU, FDA compliant]
- Superior washdown construction

Fully HACCP
and GMP
compliant



THS/MS21

Multi-Spectrum Technology for extreme compensation of the product effect



www.ceia.net



phone +39 0575 4181 • fax +39 0575 418296 • qa-detectors@ceia-spa.com

CEIA reserves the right to make changes, at any moment and without notice, to the models, their accessories and options, to the prices and conditions of sale

▶ THS 21 Metal Detectors Series with MULTI-SPECTRUM TECHNOLOGY

FEATURES

- Ultra high sensitivity to all magnetic and non-magnetic metals, including stainless steel
- Multi-Spectrum Technology for extreme compensation of the product effect
- High immunity to environmental interference
- AISI 316L stainless steel construction to IP66 and IP69K protection levels
- Control Panels listed according to UL 508A and CSA-C22.2 No. 14-05
- Automatic learning & tracking of product effect
- 500 product data memories, selectable by local programming or network software
- 10.000 storable events
- High-contrast graphical OLED display
- Local programming: 16 keys, 3 with double function
- Quick Access key for fast programming of user parameters



THS/SL21

Slim Line Metal Detector for applications in limited space.

MULTI-SPECTRUM TECHNOLOGY

Exclusively developed by CEIA, this is a unique metal detection technology that both optimizes sensitivity to all metal contaminants and minimizes product effect in a very wide range of possible products.

By recognizing the different frequency response of conductive products and metals, this innovative technology cancels product effect and maintains high performance levels for all types of metal contaminants, both magnetic and non-magnetic.

The autolearn function used by CEIA Multi-Spectrum Metal Detectors equates to the repetition of hundreds of conventional transits. It explores the whole spectrum of available frequency bands in order to determine the best operating conditions resulting in unique detection performance.



THS/21 and THS/MS21 models

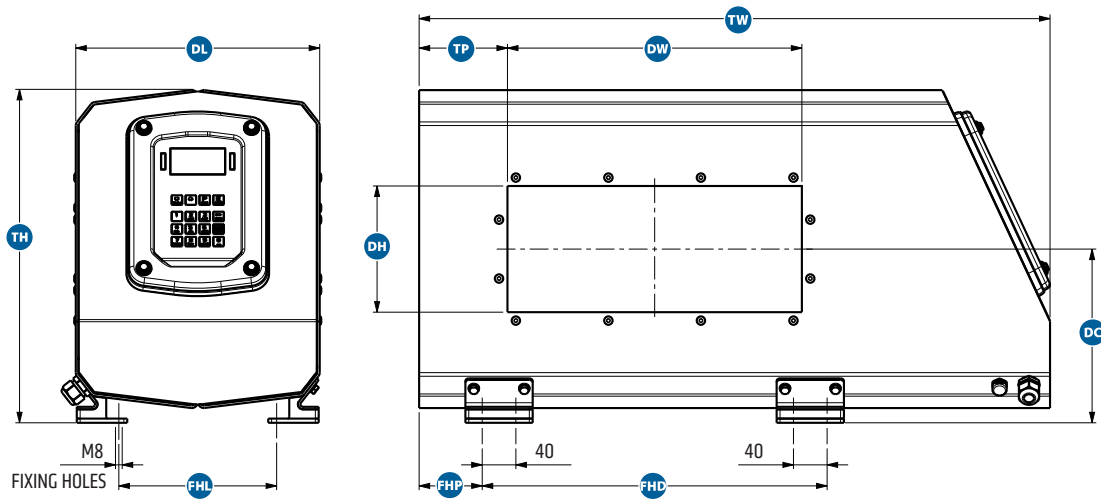

Family	DW DETECTION WIDTH	DH DETECTION HEIGHT	TH TOTAL HEIGHT	DL DETECTOR LENGTH	FHL FIXING HOLES LENGTH	TP TUNNEL POSITION	FHP FIXING HOLES POSITION	FHD FIXING HOLES DISTANCE	DC DETECTION CENTER	TW TOTAL WIDTH
A	200-250-...-1000	100 - 125 150 - 175	395	290	190	105	TP-30	DW+60	205	DW+400
B	350-400-...-800	200-225-250-275	550	390	290	160			280	DW+500
C	450-500-...-1000	300-325-350	635	490	390	210			320	DW+600
D	500-550-600- 700-...-1300	400-450-500	905	490	390	260			455	DW+700

THS/SL21 model - Slim Line Metal Detector for applications in limited space

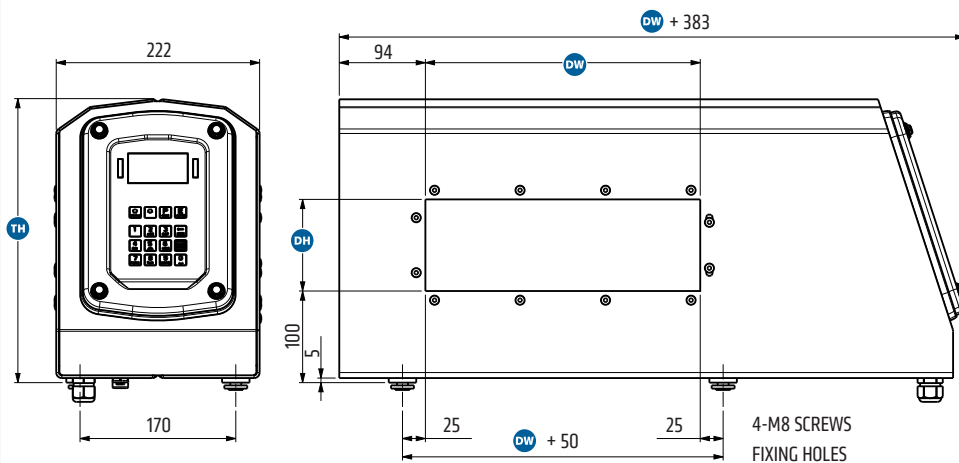

Family	DW	DH	TH
A	150-175 200-...-450	100	310
B		125 - 150	360
C		175 - 200	410
D		225 - 250	460
E		275 - 300	510

Dimensions in mm



▶ THS G21 Metal Detectors Series for FREE-FALLING PRODUCT APPLICATIONS

The THS/G21 series is designed to inspect powders, granules and other loose materials transported in free-fall through tubes and pipelines.

When fitted with a deflector, the THS/G21 becomes a system that detects and removes any contaminating metals, both magnetic and non-magnetic.

Digital analysis of the signal provided by the antenna allows extremely high levels of sensitivity, immunity to interference and operational stability to be achieved.

The very high detection speed of the THS/G21 allows the contaminated portion of product to be removed without slowing down the production flow.

Alternatively, when mounted on a packaging machine, the THS/G21 system is able to send a command to produce a double layer of packaging around the contaminated product. This can later be identified and removed from the production cycle manually.

The system is designed to communicate with external control systems, either connected directly or via a communications network.



THS/G21-F

THS/G21-F series with Reduced Metal Free Zone for limited space installations, while maintaining optimal detection of all metals.

THS/G21 Control Power Box



THS/G21 series: Standard pipe sizes available to suit all applications [ATEX version available ].



THS/G21 and THS/GMS21 models

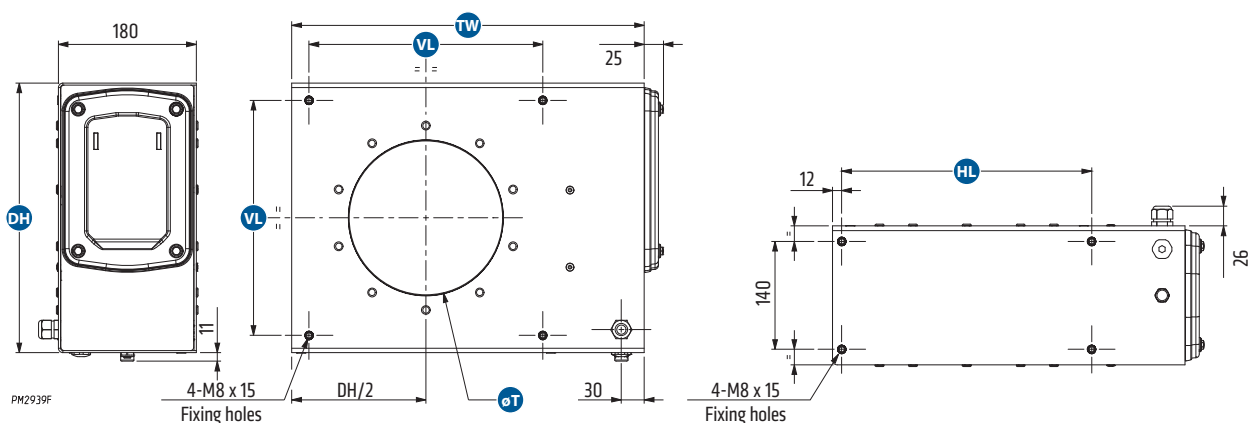

Model	T	TW	DH	VL	HL
THS/G21x-50	50	360	250	205	226
THS/G21x-100	100				
THS/G21x-150	150	410	300	255	276
THS/G21x-175	175	435	325	280	301
THS/G21x-200	200	460	350	305	326
THS/G21x-250	250	510	400	355	376

THS/G21-F and THS/GMS21-F models

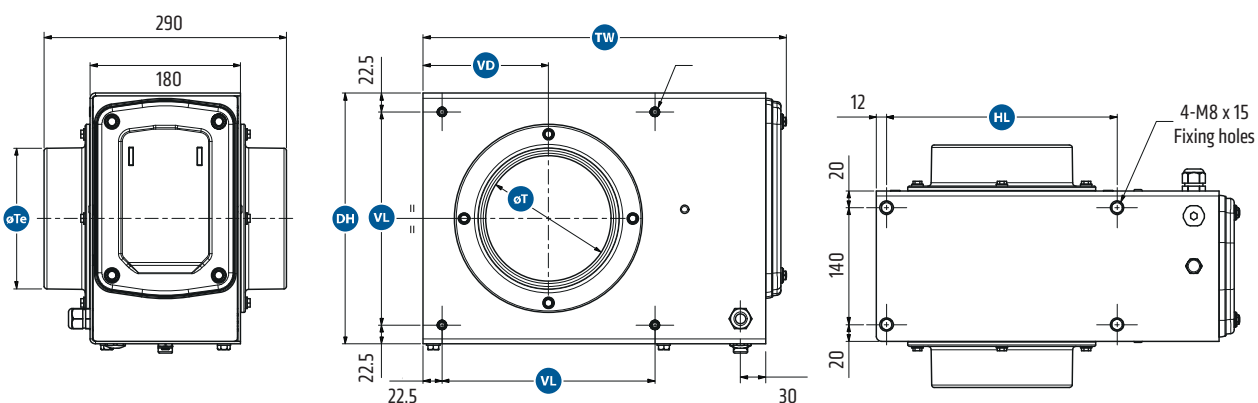

Model	T	Te	TW	DH	VL	HL	VD
THS/G21x-100F	100	118	385	250	205	226	125
THS/G21x-150F	150	168	435	300	255	276	150
THS/G21x-175F	175	193	460	325	280	301	162,5
THS/G21x-200F	200	218	485	350	305	326	175

Dimensions in mm



CEIA THS 21 Metal Detection Systems offer detection, construction quality and reliability characteristics that make them the most suitable and effective solution to automatic elimination of metal contaminants.

Fully HACCP and GMP compliant, CEIA Metal Detectors are manufactured according to ISO 9001 certified Quality System using EC and FDA approved materials.

FDA 21 PART 11 COMPLIANT

The THS 21 Metal Detector Series is a high-sensitivity, high-precision measuring instrument. The data relating to each detection and ejection are stored in an events memory and certify production quality, the inspection itself and programming operations, as well as the periodic functional test phases using standard test samples.

FDA Code Title 21 Part 11 prescribes rigorous criteria for access to programming and computer data protection which have been fully adopted in the CEIA THS 21 Series firmware.

The requirements regarding Security, Integrity and Traceability are therefore satisfied.

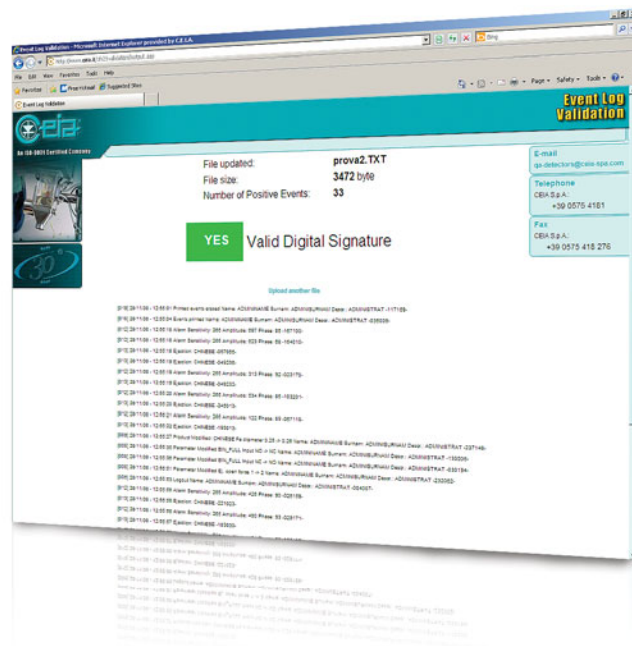

FDA 21 CFR Part 11 Compliant for data security, integrity, and traceability

Exclusive Global Auto-Learn System

Real-time embedded Self-Calibration Control

Increase in Sensitivity performance

Modern, rugged and user friendly interface



Automatic verification of the installation Quality and Environmental Compatibility

IXC and Web-Server functions



Continuous Auto-Test function ensuring maximum Production Safety



EXCLUSIVE GLOBAL AUTO-LEARN SYSTEM

The THS 21 Series employs an **exclusive Auto-Learn system** for food products which provides **simultaneous maximum sensitivity to all metals starting from a single learning transit**. The system allows optimization of the detection sensitivity to all metals with the maximum speed and precision, equivalent to hundreds of conventional learning transits: these results in levels of precision and efficiency have never been obtained before.

For products with changing or varying product signal after autolearn, the THS 21 Series includes an advanced autolearn function that runs in the background, to capture this product signal during normal production while still detecting metal. When the recording is ended, the operator has the option to analyze the data immediately, or wait until a later time when the line is stopped so as not to interrupt production. The data that was added during the background autolearn is analyzed, along with the original autolearn data, and the detection parameters are modified in order to also cancel the varying product signal.

REAL-TIME EMBEDDED SELF-CALIBRATION CONTROL

The Self-Calibration control allows maximum repeatability and performance consistency over time and with environmental changes. By means of specific signals sent to the transmission and reception chain of the Metal Detector, constant monitoring of the detection characteristics is carried out, with consequent constant compensation for any variations caused by environmental factors.

CONTINUOUS AUTO-TEST FUNCTION

ENSURING MAXIMUM PRODUCTION SAFETY

THS 21 Series Metal Detectors constantly self-test and adjust their detection characteristics during operation to ensure maximum stability and performance.

Specific electronic signals are sent to the reception and transmission channels, constantly monitoring the detection characteristics. Variations are automatically compensated for to maintain stability and cancellation of product effect. This process eliminates the need for periodic calibration and ends line arrest and product waste.

The result is the extreme stability of the system, with no variation in detection performance and reliable cancellation of product effect.

AUTOMATIC VERIFICATION OF THE INSTALLATION QUALITY AND ENVIRONMENTAL COMPATIBILITY

THS 21 Series introduces new tools for the installation and maintenance technicians which allow them to measure the environmental compatibility of the Metal Detector.

The measurements include general mechanical and electromagnetic environmental compatibility, specific electromagnetic compatibility and the automatic examination of the degree of metal interference from the conveyor belt.

This latter function becomes even more important when the high level of sensitivity of the THS 21 Metal Detector Series is taken into consideration.

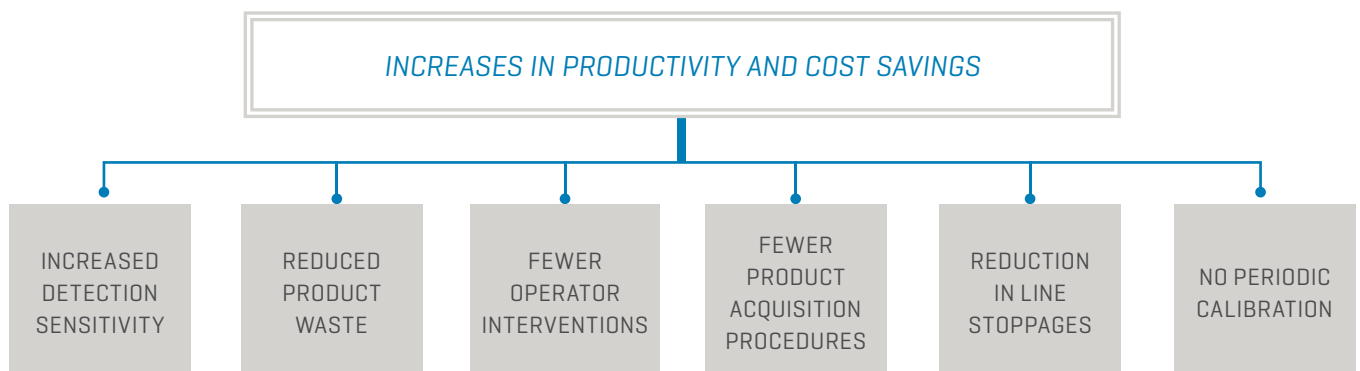

MODERN, RUGGED AND USER FRIENDLY INTERFACE



- Industrial rate design
- Rapid data entry with extended keyboard
- Easy to read, high-contrast graphic display
- Rugged, antivandalic stainless steel keyboard
Organic graph display with extremely high contrast [3000:1] and a viewing angle up to 180°, and an extended alphanumeric keypad for quick keystrokes.

- Quick Access Function
A new function, activated simply by pressing a dedicated key, allows the most frequently-used functions to be directly recalled. These functions are programmable by the operator.
- Large Product Memory: 500 entries with easy alphabetical sorting and pattern matching



RUGGED, ANTIVANDALIC STAINLESS STEEL KEYBOARD

EASY TO READ, HIGH-CONTRAST GRAPHIC DISPLAY

LARGE PRODUCT MEMORY

```

===== Prod. =====
FRESH ROLLED MEAT
FRESH SLICED
♦ FROZEN VEAL
FROZEN READY MEAL
Search: FR
    
```

QUICK ACCESS FUNCTION

```

===== QUICK ACCESS =====
0) Products
1) Autolearn
2) Sensitivity
3)
4) Reset
  ↓ Scroll down
    
```

SOPHISTICATED INTERFACE CAPABILITIES



» BLUETOOTH® CONNECTIVITY

In the THS/21 Series, local connection to the maintenance technician’s computer no longer requires physical access to the interior of the detector or the use of unwieldy connection cables. The Bluetooth connection can be used for programming, monitoring of the signals via the CEIA MD-Scope program and the transfer of the data contained in the Metal Detector’s events memory.

» NETWORK COMMUNICATION CAPABILITIES

The Metal Detector can be linked to an Ethernet network [optional IXC module required]. In association with the THS Production Plus Software it enables remote management of production, collection of all technical and operational events, generation of statistical and traceability reports in compliance with FDA 21 CFR part 11 requirements.

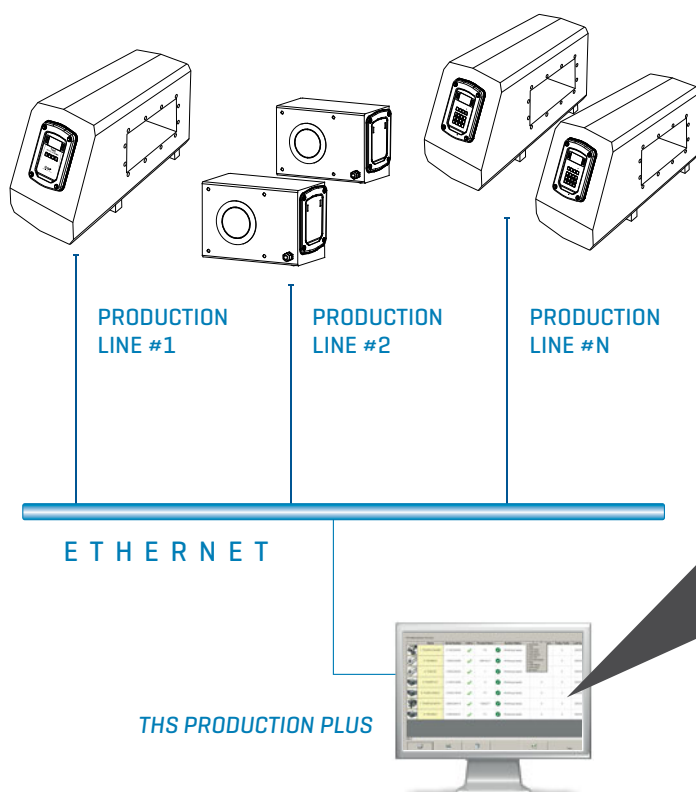

» MD-SCOPE

Software Diagnostic Package complete with connector cable and hardware key:

- Remote programming
- Signal input/output
- Alarm threshold and amplitude of the signal
- Oscilloscope functionalities

» THS PRODUCTION PLUS

- Connects and Acquires Data from Multiple THS Detectors via Ethernet LAN
- Provides Connection to an External Database and Definition of a Programmable Block of SQL Instructions for each Metal Detector Event
- Enables Data Base Management and Back-Up of Metal Detector events
- Report Data Exportable in HTML and CSV format
- Provides User Authentication and Manages Electronic Signatures and Records
- Allows Data Integrity and Operator Auditing
- FDA Requirements Compliant, Title 21 of the Code of Federal Regulations [CFR]
- Email sender

Name	Serial Number	Online	Product Name	System Status	Today Tests	Last S...
1. THSIPH21N-WP	21100208062	✓	P2	Working properly	0	28/20
3. THSGS21	21000224065	✓	DEFAULT	Working properly	0	28/20
4. THSQ21E	21000238032	✓	Y	Working properly	0	28/20
5. THSFFV21	21100213069	✓	A	Working properly	0	28/20
6. THSPLVMS21	21000218048	✓	P1	Working properly	0	28/20
7. THSIPH21N-FFV	20900246015	✓	TABLET1	Working properly	0	28/20
8. TPLMS21	21000205021	✓	P1	Working properly	0	28/20

IXC AND WEB-SERVER FUNCTIONS



>> IXC MODULE

- Gateway to THS Production Net Management System
- Integrated Web-server
- Dual 100base-T Ethernet
- Dual Full Speed USB interface
- Wi-Fi 802.11b/g
- 100.000 events internal data logger
- Additional web-server functionality

>> WEB-SERVER INTERFACE

- Built-In MD SCOPE
The MD Scope functions (including oscilloscopes) are available to every user connected to the Metal Detector via Ethernet or WiFi.
- Status
Replicates every message displayed by the THS (updated each 5 s).
- Products
Displays the list of products stored into the THS memory, the selected product is shown in green. This page allows the product to be changed.
- Products Export
Allows selection of all or part of the products stored in the THS memory in order to export them.
- Products Import
Allows importation of all or part of the products exported.
- Buffer Export
Allows exportation of events occurred in a selected time frame.
- Configuration Backup/Restore
Allows backup or restoring of the connected system configuration.
- Configuration Export/Import
Allows the configuration to be exported or imported from other Metal Detectors of the same model, installed on the same system.

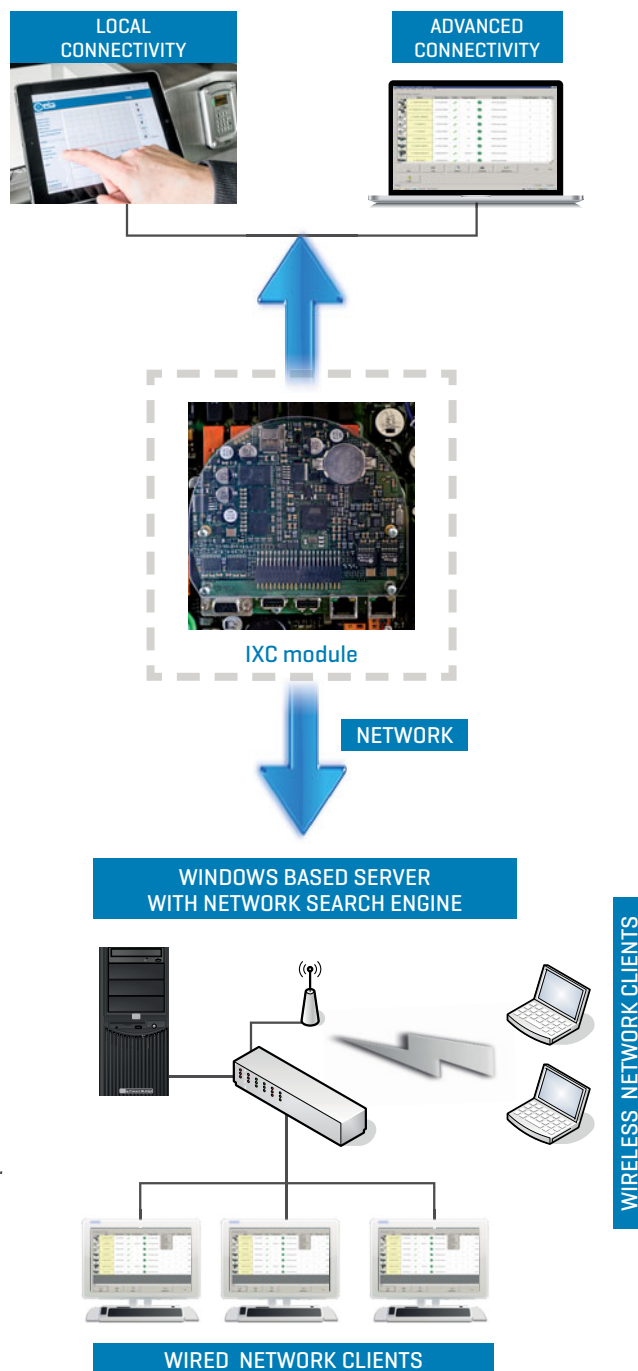

SPECIFICATIONS



SPECIAL FEATURES

THS/21 - THS/MS21

	Detection sensitivity	Ultra High
	Immunity to environmental interference	High
	Data display type	High-contrast graphical OLED 128x64 pixels
	Local programming	16 keys, 3 with double function
	Control Power Box or Conveyor Control System according to Standards UL 508A and CSA-C22.2 No. 14-05	on request
	Audio and visual detection indicators	
	Display of the signal level by means of bar graph	
	Inspected/contaminated product counter	
	ISO 9001 certified manufacturer	
	Extremely compact probe, on SL (Slim Line) version	
	Detector for magnetic and non-magnetic metals, for use with different types of product thanks to selection of the operating frequency	
	Autolearn and automatic tracking of the product effect	
	Probe with circular opening for checking material transported in tubing, on THS/G21 series	
	Up to 500 product data memories, selectable by local programming or network software	
	Up to 40 definable users with username and password	
DATA MANAGEMENT	Management of electronic production data and electronic signatures as per CFR 21, Part 11	Data security
		Data integrity
		Data traceability
EVENTS STORAGE	Complete monitoring of occurred events	Ejections
		Test results
		Programming accesses
		Programming operations
		Faults
I/O INTERFACES	RS232, Auxiliary RS232, Bluetooth, Ethernet/WiFi/USB (optional)	
SIGNALLING	Acoustic	Via internal buzzer
	Optical	Graphic display with bar-graph indication
		Light indicators on control unit: RED: Alarm or Fault / GREEN: Power on
PROGRAMMING	Local: built-in keyboard and high-contrast display	
	Remote: through computer connected via Bluetooth, RS232, Ethernet or WiFi and managed with CEIA MD Scope software, THS Production Plus software or any other terminal emulation program or through Web Server (with optional IXC card)	
SAFETY AND SECURITY	Protection degree	THS/21 - THS/MS21 IP66 - IP69K
		On UL versions, the Control Power Box and Conveyor Control System have a 4X-12 certified degree of protection
	Electrical insulation	Galvanic isolation of the mains voltage
		Compliant with international standards for safety and radio interference

SPECIFICATIONS



SUPPLY	Control Power Box	Main voltage	100-240 VAC
		Frequency and phase	50/60 Hz - single phase
		Full load current (FLA)	2.2 A
	Conveyor Control System	Main voltage	115 V: 100-120 VAC
230 V: 200-240 VAC			
Frequency and phase		50/60 Hz - single phase	
Full load current (FLA)		115 V version: 11.2 A	
		230 V version: 11.4 A	
Connected motor nominal 200÷240 V triphase voltage			
Connected motor maximum power	115 V version: 0.37 kW (0.5 hp)		
	230 V version: 0.75 kW (1 hp)		
Small-size power supply card00211AL_	Power supply voltage	20÷30 Vdc o Vac; 2A max.	
	ENVIRONMENTAL CONDITIONS	Temperature	Operating
Storage			-40 – +70 °C
Relative humidity		Operating / Storage	5 – 90 %, non-condensing
MANAGEMENT SOFTWARE	THS Production software for statistical and operational management of networked THS systems		
	MD-SCOPE for maintenance and programming operations		



COSTRUZIONI ELETTRONICHE AUTOMATISMI INDUSTRIALI
 Zona Industriale 54/G, 52041 Vicinomagno - Arezzo (ITALY)
 Tel.: +39 0575 4181 Fax: +39 0575 418296 E-mail: qa-detectors@ceia-spa.com