



# THS 21 SERIES

## Quality Control at its finest



### CONVEYOR INSPECTION SYSTEMS

Supermarket  
specifications  
compliant

#### FEATURES

- Conveyor belt integrated with Metal Detector and ejection system
- Full compliance with HACCP criteria
- Detection and ejection of magnetic, non-magnetic and stainless steel metals contaminants
- Automatic learning & tracking of product effect
- Digitally-adjustable belt speed
- Structure and components in AISI 316L stainless steel and food-compatible plastic parts [EU, FDA compliant]
- Multiple ejection systems available: belt stop, air blast, pusher arm and retractable
- Maximum flexibility: all components are reversible



THS/MBB  
Modular Conveyor  
Belt System



www.ceia.net



phone +39 0575 4181 • fax +39 0575 418296 • qa-detectors@ceia-spa.com

CEIA reserves the right to make changes, at any moment and without notice, to the models, their accessories and options, to the prices and conditions of sale

**CEIA is a manufacturing company specialized in the design, engineering and production of Metal Detectors and Quality Control equipment.**



**CEIA THS 21 Conveyor Inspection Systems satisfy the most stringent requirements for functionality, compact construction, accuracy and reliability of response against accidental metal contamination in food products.**

CEIA, leading manufacturer of industrial metal detectors, offers a **complete range of solutions for inspecting food products, both loose and packaged.** The line of Quality Control Detectors includes the Conveyor Inspection Systems, featuring state-of-the-art performance and full compliance with industrial sector regulations.

**THS 21 Conveyor Inspection Systems offer total integration between CEIA's high-performance THS 21 Metal Detector and a hygienic structure in AISI 316L stainless steel, equipped with digital control of the speed and of the stages of ejection of non-conforming products.** CEIA's THS 21 are available in a wide range of sizes covering the different application requirements.

The supporting structure, the Metal Detector and the belt control box are in stainless steel. The inspection system is certified fully compatible with food product handling (FDA compliant) requirements, as is the protective cover of the ejection area and the container for rejected products.

**MULTI-SPECTRUM TECHNOLOGY**

Exclusively developed by CEIA, this is **a unique metal detection technology that both optimizes sensitivity to all metal contaminants and minimizes product effect in a very wide range of possible products.**



By recognizing the different frequency response of conductive products and metals, this innovative technology cancels product effect and maintains high performance levels for all types of metal contaminants, both magnetic and non-magnetic.

**The autolearn function used by CEIA Multi-Spectrum metal detectors** equates to the repetition of hundreds of conventional transits. It explores the whole spectrum of available frequencies in order to determine the best operating conditions resulting in unique detection performance.

**FULL COMPLIANCE WITH HACCP CRITERIA**

- IP65/69K compliant
- Structure and components in AISI 316L stainless steel and plastics EU, FDA compliant
- Superior washdown construction



**EASY TO CLEAN AND INSPECT**

- Conveyor belt can be removed without any tool



The line of CEIA Quality Control equipment includes the Conveyor Inspection Systems, featuring state-of-the-art performance and **full compliance with industrial sector regulations.**



CEIA THS 21 Metal Detectors Series has been **designed to manage all the functions required by the transport systems.**

**UNEQUALLED INTEGRATED I/O AND COMMUNICATION CONNECTIVITY PERFORMANCE**

- Control of the belt motor, with speed adjustment
- Automatic ejection management with synchronization of the product transit
- Automatic synchronization with adjacent transport systems
- Verification of the availability of compressed air
- Bar-code readers support to automatically select the product related program in real time
- Verification of the successful ejection of the contaminated product
- Verification of the presence and space availability of the contaminated product container
- Management of encoders for a belt speed monitoring
- Remote management via Ethernet/Wi-Fi

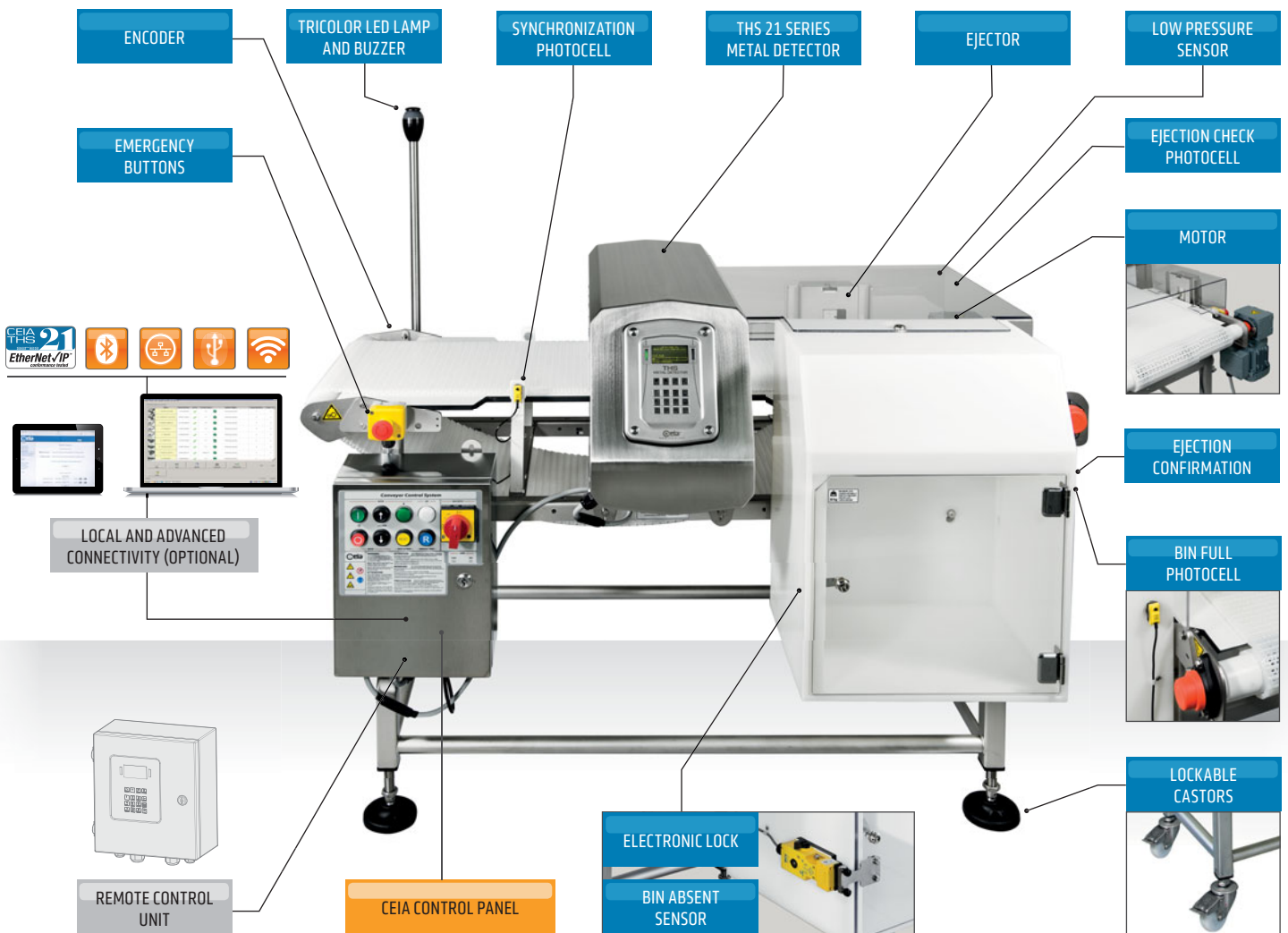

CEIA THS 21 Conveyor Inspection Systems are available in a **wide range of sizes covering different application requirements.**

The following tables provides a list of the standard available characteristics and dimensions.



		THS/FBB	THS/MBB	THS/MBR	THS/RB
Belt Type	Flat	•			
	Modular		•	•	
	Round belt				•
Metal Detector	THS/21x	•	•	•	• <sup>[2]</sup>
	THS/MS21x	•	•	•	• <sup>[2]</sup>
	THS/21E	•	•	•	• <sup>[2]</sup>
	THS/MN21	• <sup>[1]</sup>			
Ejection Type	External signalization relay				•
	Belt stop	•	•		
	Pneumatic piston	•	•		
	Air blow	•	•		
	Reversing belt	•			
	Retracting belt			•	
Belt Length [mm] <b>BL</b>	800				•
	1000	•	•		
	1300	•	•		
	1500	•	•		
	1700			•	
	1800	•	•		
	2000	• <sup>[3]</sup>		•	
Belt Width [mm] <b>BW</b>	200	•	•		•
	300	•	•	•	•
	400	•	•		•
	450			•	
	500	•	•		
	600		•	•	
	800			•	
Belt Height [mm] <b>BH</b>	700	•	•		
	745 (only with lockable castors)	•	•		
	775	•	•		
	825	•	•		
	875	•	•	•	•
	920 (only with lockable castors)	•	•		
	950	•	•		
	1000	•	•		
	1125	•	•		
Component inversion	Antenna/PSU box	•	•	•	•
	Ejection system	•	•		

<sup>1</sup> Only with belt length of 2000 mm  
<sup>2</sup> Only SL (Slim Line) version  
<sup>3</sup> Only with THS/MN21 detector

For details of customized versions with different dimensions and configurations, contact our Sales Department.



# THS/FBB

## FLAT CONVEYOR BELT CONFIGURATION

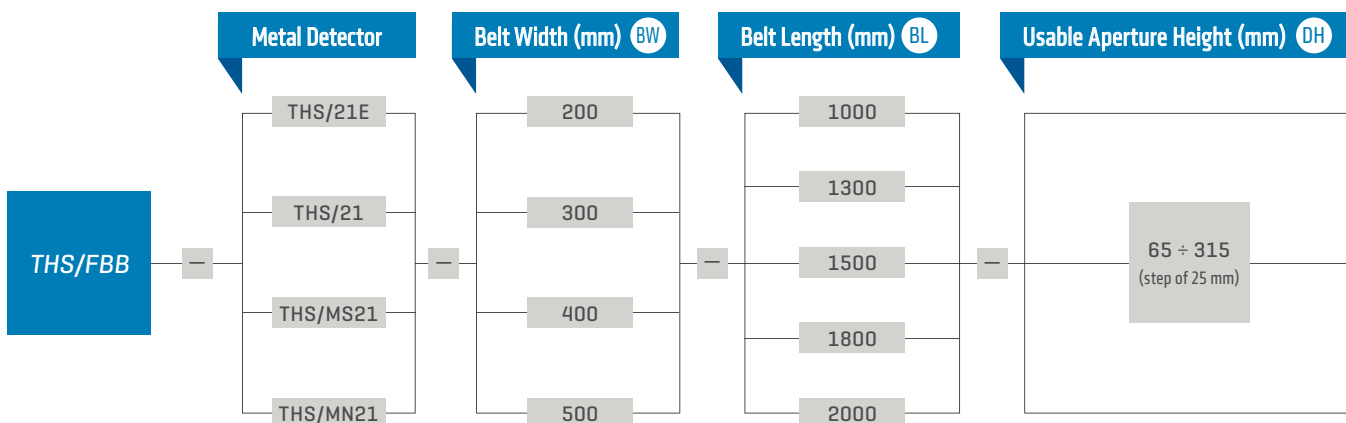

	THS/FBB-X-X-1000-X	THS/FBB-X-X-1300-X	THS/FBB-X-X-1500-X	THS/FBB-X-X-1800-X	THS/FBB-X-X-2000*-X
Signalling lamp	●	●	●	●	●
Synchronization photocell	●	●	●	●	●
Belt variable speed	●	●	●	●	●
Belt height					
700 mm	○	○	○	○	-
745 mm (only with lockable castors)	○ <sup>(1)</sup>	○ <sup>(1)</sup>	○ <sup>(1)</sup>	○ <sup>(1)</sup>	-
875 mm	●	●	●	●	●
920 mm (only with lockable castors)	○ <sup>(1)</sup>	○ <sup>(1)</sup>	○ <sup>(1)</sup>	○ <sup>(1)</sup>	-
Height extension					
75 mm	○	○	○	○	○
125 mm	○	○	○	○	○
250 mm <sup>(3)</sup>	○	○	○	○	○
Stand type					
Adjustable feet ±75 mm	●	●	●	●	●
Lockable castors ±75 mm	○ <sup>(1)</sup>	○ <sup>(1)</sup>	○ <sup>(1)</sup>	○ <sup>(1)</sup>	-
Ejection system					
None (belt stop in case of alarm)	●	●	●	●	●
Reject pusher cylinder	-	○ <sup>(3)</sup>	○ <sup>(3)</sup>	○ <sup>(3)</sup>	○
Reject air jet	-	○ <sup>(3)</sup>	○ <sup>(3)</sup>	○ <sup>(3)</sup>	○
Reject bin					
Standard	-	○	○	○	○
Large	-	-	-	○	-
Side panels for product containment	○	○	○	○	○
Ejection confirmation	-	○	○	○	○
Ejection confirmation, bin full alarm, low pressure alarm	-	○	○	○	○
Emergency activation if bin absent	-	○	○	○	○

● Standard ○ Accessory / Option

<sup>1</sup> Available only on some models of standard systems, without height extensions <sup>2</sup> Applicable only on belt height 875 - <sup>3</sup> Available only on some configurations -

\* Only with THS/MN21 probe

# THS/MBB

## MODULAR CONVEYOR BELT CONFIGURATION

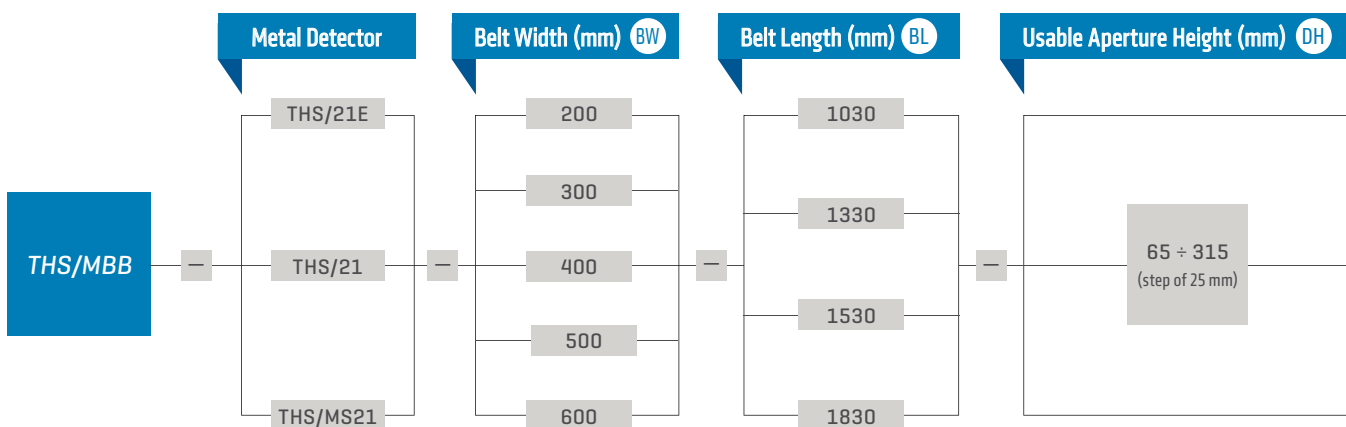

		THS/MBB-X-X-1030-X	THS/MBB-X-X-1330-X	THS/MBB-X-X-1530-X	THS/MBB-X-X-1830-X
Signalling lamp		●	●	●	●
Synchronization photocell		●	●	●	●
Belt variable speed		●	●	●	●
Belt type	Flush grid	●	●	●	●
	Flat top	○	○	○	○
Belt height	700 mm	○	○	○	○
	745 mm (only with lockable castors)	○ <sup>[1]</sup>	○ <sup>[1]</sup>	○ <sup>[1]</sup>	○ <sup>[1]</sup>
	875 mm	●	●	●	●
	920 mm (only with lockable castors)	○ <sup>[1]</sup>	○ <sup>[1]</sup>	○ <sup>[1]</sup>	○ <sup>[1]</sup>
Height extension	75 mm	○	○	○	○
	125 mm	○	○	○	○
	250 mm	○ <sup>[2]</sup>	○ <sup>[2]</sup>	○ <sup>[2]</sup>	○ <sup>[2]</sup>
Stand type	Adjustable feet ±75 mm	●	●	●	●
	Lockable castors ±75 mm	○ <sup>[1]</sup>	○ <sup>[1]</sup>	○ <sup>[1]</sup>	○ <sup>[1]</sup>
Ejection system	None (belt stop in case of alarm)	●	●	●	●
	Reject pusher cylinder	-	○ <sup>[3]</sup>	○ <sup>[3]</sup>	○ <sup>[3]</sup>
	Reject air jet	-	○ <sup>[3]</sup>	○ <sup>[3]</sup>	○ <sup>[3]</sup>
Reject bin	Standard	-	○	○	○
	Large	-	-	-	○
Side panels for product containment		○	○	○	○
Ejection confirmation		○	○	○	○
Ejection confirmation, bin full alarm, low pressure alarm		○	○	○	○
Emergency activation if bin absent		○	○	○	○

● Standard ○ Accessory / Option <sup>1</sup> Available only on some models of standard systems, without height extensions

<sup>2</sup> Applicable only on belt height 875 - <sup>3</sup> Available only on some configurations

# THS/MBR

## MODULAR CONVEYOR RETRACTABLE BELT CONFIGURATION

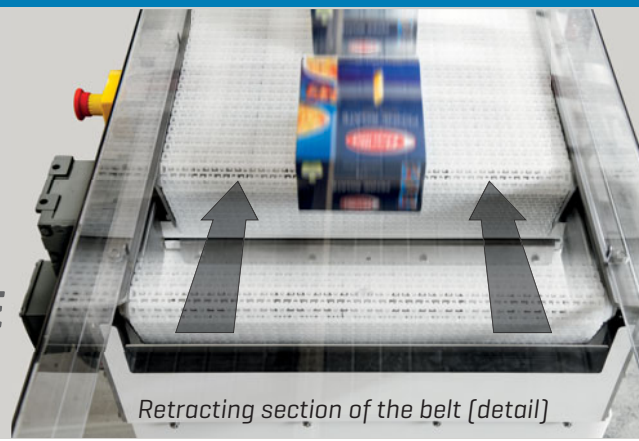

Retracting section of the belt [detail]

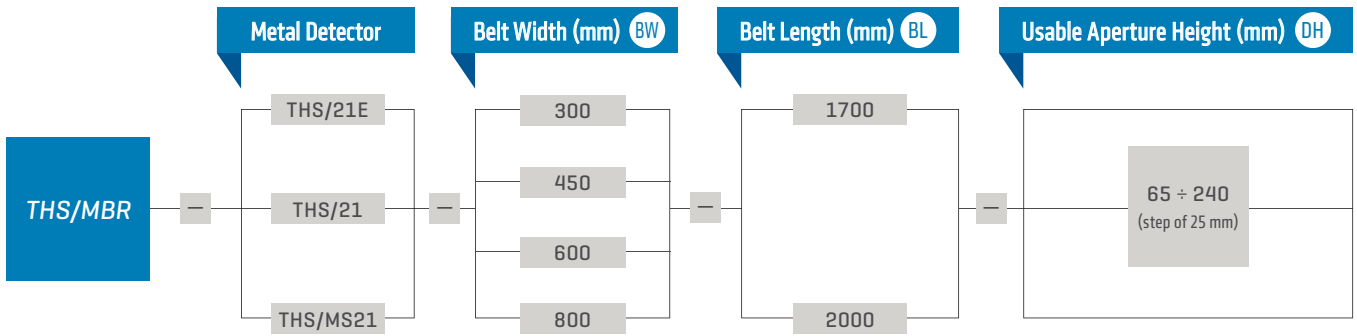

		THS/MBR-X-X-1700-X	THS/MBR-X-X-2000-X
Signalling lamp		●	●
Synchronization photocell		●	●
Belt variable speed		●	●
Belt type	Flush grid	●	●
	Flat top	○	○
Belt height	875 mm	●	●
Stand type	Adjustable feet ±75 mm	● [x4]	● [x6]
Reject bin	Standard	●	●
Side panels for product containment		○	○
Ejection confirmation, bin full alarm		○	○
Low pressure alarm		○	○
Emergency sensor on rejection bin		○	○

● Standard ○ Accessory / Option

**THS/MBR**  
Modular  
Conveyor Belt  
with retractable  
ejection system



# THS/RB

## ROUND CONVEYOR BELT CONFIGURATION



### TOOL-FREE BELT REMOVAL



Remove the four locking pins

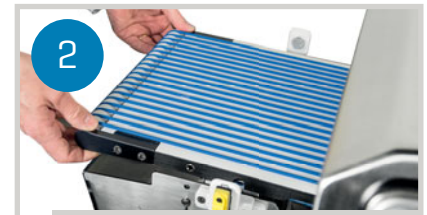

Lift the belt and the skid plate

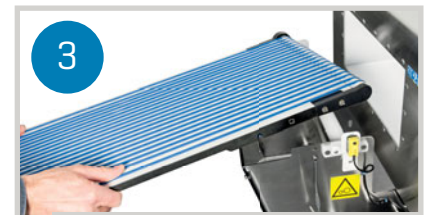

Remove the belt and the skid plate from the conveyor

### METAL DETECTION SYSTEM WITH ROUND BELT FOR IN-LINE APPLICATIONS

The CEIA THS/RB-800 has been developed as a solution for seamless integration with any checkweigher system and other in-line applications. The main design considerations being a conveyor which allows the best sensitivity performance of the metal detector to be maintained throughout its lifetime.

At a length of 800 mm its footprint is small, and therefore it fits in the line taking up minimal space. The straightforward electrical integration required allows the metal reject function to be carried out separately using the existing reject systems. Conveyor belt maintenance is minimal due to its unique design, which permits skidplate removal in seconds without the requirement for tools.



The THS/RB-800 is an innovative and unique system designed for seamless and highly compatible integration into standard checkweigher systems and other in-line applications, so that maximum detection sensitivity can always be achieved.

The THS/RB-800 offers a high performance cost effective solution where space and best performance are critical.

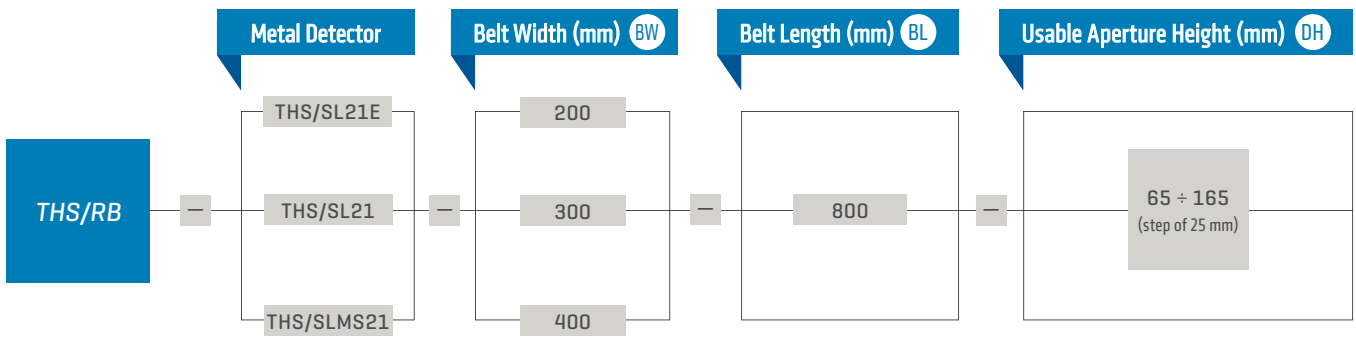

	THS/RB-X-X-800-X
Synchronization photocell	●
Variable speed	●
Ejection output relay signal	●
Built-in encoder for following conveyor speed sensing	○

● Standard ○ Option



### EXAMPLES OF INSTALLATION

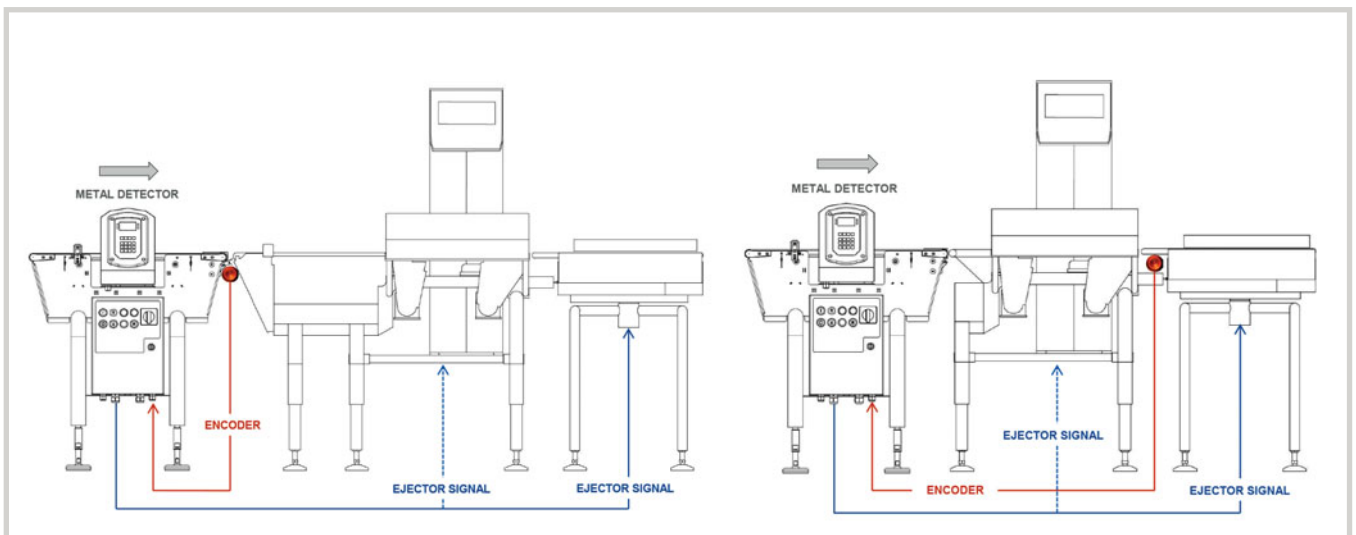

MECHANICAL DRAWINGS



THS/FBB with family A and B detectors

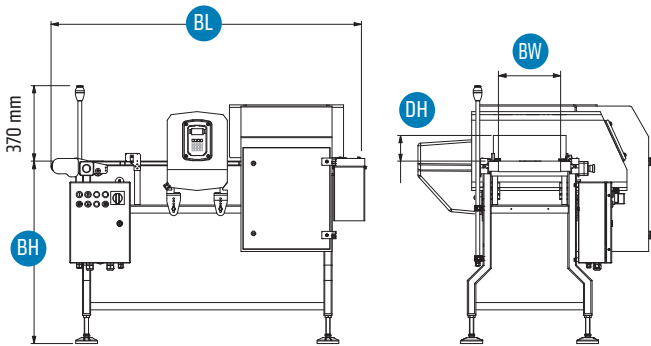

THS/FBB with family C detectors

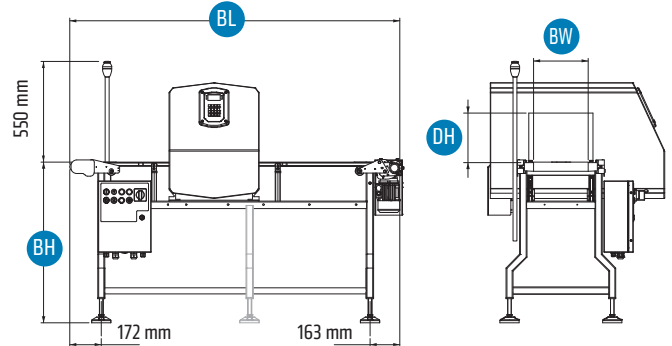

THS/MBB with family A and B detectors

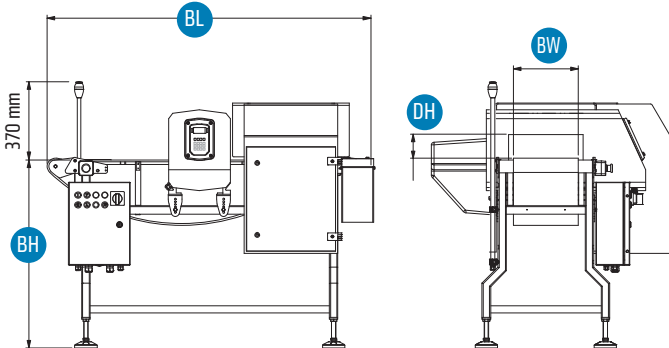

THS/MBB with family C detectors

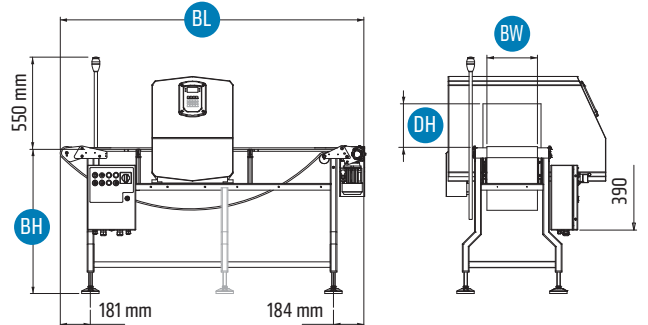

THS/MBR

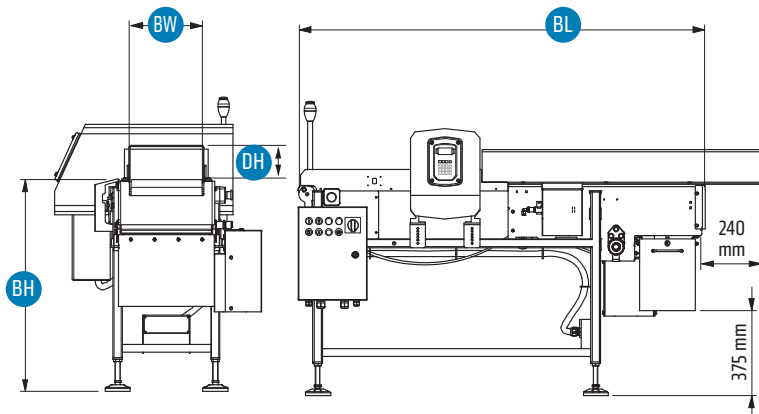

THS/RB

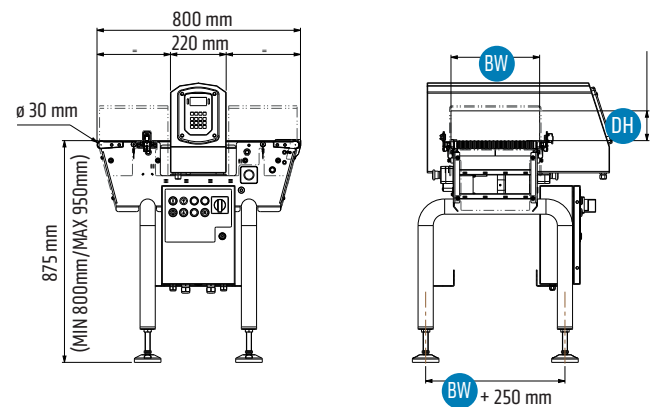

# SPECIFICATIONS



## SPECIAL FEATURES

- Conveyor belt with integrated THS/21x Metal Detector and ejection system
- Full compliance with HACCP criteria
- Structure and components in stainless steel and food-compatible plastic parts (EU, FDA compliant)
- Conveyor belt (flat or modular) made from certified food-safe materials
- System designed to the latest, most stringent safety standards
- Conveyor Control System compliant with UL 508A and CSA-C22.2 No. 14-05 standards (on request)
- High-reliability motor with stainless steel protective cover, high drive capacity version
- Easy belt alignment
- Digital speed adjustment
- Quick and easy to clean
- Easy maintenance and inspection
- Up to 500 product data memories, selectable by local programming or network software
- Up to 40 definable users with username and password

## DATA MANAGEMENT

- Electronic records and Signature Management
- compliant with CFR 21, Part 11
- Data security
- Data integrity
- Data traceability

## EJECTION SYSTEMS

- Belt stop, pneumatic pusher ejection, air jet ejection, deviator arm, belt reversing (only on THS/FBB), belt retraction (THS/MBR).
- Other modes available upon request.

## EVENTS STORAGE

- Complete monitoring of occurred events
- Ejections
- Test results
- Programming accesses
- Programming operations
- Faults

## I/O INTERFACES

- RS232, Auxiliary RS232, Bluetooth, Ethernet interface (on request), WI-FI and USB (on request)

## SIGNALLING

- Acoustic
- Optical
- Via external buzzer and internal buzzer
- Graphic display with bar-graph indication
- Light indicators on control unit
- External beacon
- RED: Alarm or Fault
- GREEN: Power on
- RED: Alarm or Fault
- AMBER: Alarm (optional)
- BLUE: Test request (optional)

## PROGRAMMING

- Local: built-in keyboard and high-contrast display
- Remote: through computer connected via Bluetooth, RS232, Ethernet or WiFi and managed with CEIA MD-Scope software, THS Production Plus software or any other terminal emulation program or through Web Server (with optional IXC card)

## INPUTS

- Conveyor Control System
- Ejection confirmation, Photocell, Reset, Low pressure, Encoder, Bin full, Emergency buttons, Barcode reader, Following Conveyor, Inhibition, Bin absent, Ejector position check, Ejector check

## OUTPUTS

- Conveyor Control System
- Test request, Upstream conveyor, System ready, Ejection in progress, Alarm, Ejector, External beacon

## SELF-DIAGNOSIS SYSTEM

- An internal self-diagnosis system continuously monitors Metal Detector functional efficiency. In the event of a fault, a message is shown on the control display and all alarm indicators are activated together with corresponding relays.



## SPECIFICATIONS



### SAFETY AND SECURITY

Protection degree	THS/21E Metal Detector	IP65
	THS/21 - THS/MS21 Metal Detectors	IP66 – IP69K
	THS/FBB, THS/MBB, THS/MBR	IP65
	THS/RB-800	Control System certified: Type 4X-12 (UL 50) available Conveyor System: IP54 (IEC 529) - IP69K available on request
On UL versions, the Conveyor Control System has a 4X-12 certified degree of protection		
Noise emissions	Noise level as per Directive 2006/42/EC	<70 dB(A); <130 dB(C)
Electrical insulation	Compliant with international standards for safety and radio interference	

### SUPPLY

Control Power Box	Voltage	115 V: 100-120 VAC
		230 V: 200-240 VAC
	Frequency and phase	50/60 Hz - single phase
	Full load current (FLA)	115 V: 11.2 A (15.6 A for THS/MN21) 230 V: 11.4 A (15.8 A for THS/MN21)
Motor	Nominal voltage	230 V triphase
	Maximum power	115 V: 0.37 kW (0.5 hp) 230 V: 0.75 kW (1 hp)
Compressed air	Pressure	600-1000 kPa
	Flow	50 litres/min (piston ejector) 600 litres /min (air blow ejector, optional)

### ENVIRONMENTAL CONDITIONS

Temperature	Operating	-10 to +55 °C
	Storage	-40 to +70 °C
Relative humidity	Operating - Storage	5 to 90 %, non-condensing
Altitude	≤1000 m characteristic. For details of other altitudes, contact the Sales Department	

### MANAGEMENT SOFTWARE

THS Production software for statistical and operational management of networked THS systems
MD-SCOPE for maintenance and programming operations



COSTRUZIONI ELETTRONICHE AUTOMATISMI INDUSTRIALI  
Zona Industriale 54/G, 52041 Vicinomagno - Arezzo [ITALY]  
Tel.: +39 0575 4181 Fax: +39 0575 418296 E-mail: qa-detectors@ceia-spa.com